

HiTRON

18-36VDC INPUT RANGE DC-DC CONVERTER HALF SIZE HOT-SWAP CONDUCTION-COOLED CompactPCI QUAD OUTPUT 205 WATTS ACTIVE CURRENT SHARING SWITCHING POWER SUPPLIES HDC202C-24B-490(E) SERIES



FEATURES:

- 205W HALF SIZE 3U X 4HP PACKAGE
- 16.6-36VDC (NOMINAL 24/28VDC) INPUT
- CONDUCTION-COOLED
- N+1 REDUNDANCY, HOT-SWAPPABLE & ACTIVE CURRENT SHARING
- WIDE OPERATING TEMPERATURE
- EMI MEET EN 55022 / FCC CLASS A
- FULLY COMPLIANT WITH PICMG
- CE MARKING LEVEL 3 COMPLIANCE
- EN50155 STANDARD COMPLIANCE

SPECIFICATION

INPUT SPECIFICATION

Input Voltage: Typ. 16.6-36Vdc.
Nominal input 24 or 28Vdc.
Input Connector: Positronic 47-pin PCIH47M400A1.
Inrush Current: Active Inrush Current Limit Circuit
Peak 28A (300uS) at input 36Vdc.
Input Current: Typ. 10.67A at nominal input 24Vdc.
Input Under & Over Voltage Protection: Built-in.
Dielectric Withstand: Meet IEC 60950-1 regulation.
EMI: Meet CISPR EN 55022 Class A.
Radiated Susceptibility: EN61000-4-3 Level X (20V/m).
Surge: Meet EN6100-4-5 Level 3, L-L 2KV, L-G 2KV.
Conducted Disturbance: EN61000-4-6 Level X (20V/m).
Remote ON/OFF: Available at [INH#] & [EN#] pins.
Power Fail Signal: Available at [FAL#] pin.
Over Temperature Protection (OTP): Installed NTC for thermal sensor at [DEG#] pin.

OUTPUT SPECIFICATION

Output Voltage: See Ratings Chart.
Output Current: See Ratings Chart.
Output Wattage: Typ. 205Watt continuous.
Output Connector: Positronic 47-pin PCIH47M400A1.
Line Regulation: Typ. $\pm 0.5-3\%$.
Load Regulation: Typ. $\pm 1-5\%$.
Noise & Ripple: Typ. 1% peak to peak.
Adjustability: Available at VO1,2&3.
Remote Sensing: Available at VO1,2&3.
Hot-Swap: Available.
N+1 Redundancy: Installed with OR-ing devices at all outputs for N+1 redundancy.
Current Sharing: Active current sharing at VO1,2&3.
Power OK Signal: Available for all outputs.
Over Voltage Protection (OVP): Built-in at all outputs.
Over Current Protection (OCP): Installed at each rail.
Overload Protection (OLP): Fully protected against output overload or short circuit. Typ. set at 105-130% max. load.

GENERAL SPECIFICATION

Efficiency: Typ. 82 % at 24Vdc.
Switching Frequency: 210-240KHz.
Circuit Topology: Active Clamp Forward circuit with M.A.
Transient Response: Peak transient less than 300mV and recovers within 2mS after 50% load-change.
Construction: 3U x 4HP half-size CompactPCI
Front Panel with Extractor handle.
Wedge Lock : ACCR MVBA260-4.80ETM2.5LK x 2pcs,
Calmark MVA260-4.80ETM2.5LK x2pcs or
ELMA 325-04.80MVBA3TM2.5LK x 2pcs
(Option & Consigned by Customer)
Conformal Coating.

Operating Temperature: -40°C to +100°C
without air flow and derate linearly from 100% power at +85 °C to 70% power at +100 °C.
(Temp. measured at top cover or card edge. Refer to de-rating chart.).
Storage Temperature: -55°C to +100°C.
Cooling: Top-cover conduction cooled.
Power Density: 7.4 Watts /Cubic Inch.
Safety Standard: IEC 60950-1 Class I.
CE Standard: Meet Level 3 Criteria A.
Shock: 45G max
Vibration: Random vibration, 10Gmax.

NOTE: (1) All measurement are at nominal input, full load and +25°C unless otherwise specifications.
(2) Constant Current limit for each o/p & 3-7 seconds shutdown. Peak Current Timer is installed.
(3) Due to requests in market and advances in technology, specifications subject to change without notification.
(4).125 degree C OS-CON Long-life Solid capacitors are installed.

OUTPUT VOLTAGE / CURRENT RATINGS CHART

QUAD OUTPUT

MODEL NO.	MAIN +VO1 @★#≡⊙					AUX. +VO2 ▲★#≡⊙@					AUX. +VO3▲★#≡⊙@					AUX. -VO4 ▲⊙★				
	Min.	Typ.	Volt.	Max.	Pk.	Min.	Typ.	Volt.	Max.	Pk.	Min.	Typ.	Volt.	Max.	Pk.	Min.	Typ.	Volt.	Max.	Pk.
HDC202C-24B-490(E)	1A	20A	+5V	27A	30A	0A	10A	+3.3V	15A	20A	0A	5A	+12V	6A	7A	0A	1A	-12V	1.5A	2A

Symbol: "★" OVP "@ " Adjustable. "#" Remote sensing. "≡" Load Sharing. "⊙" Installed with Or-ing diode. "▲" Magnetic Amplifier.

Remark: 1.Total maximum power of VO1 and VO2 should be less than 150W.

2. Max. load is the continuous operating load of each rail. But the max. load of each rail can't be drawn from all outputs at the same time.

MECHANICAL DIMENSIONS: MM [INCHES]

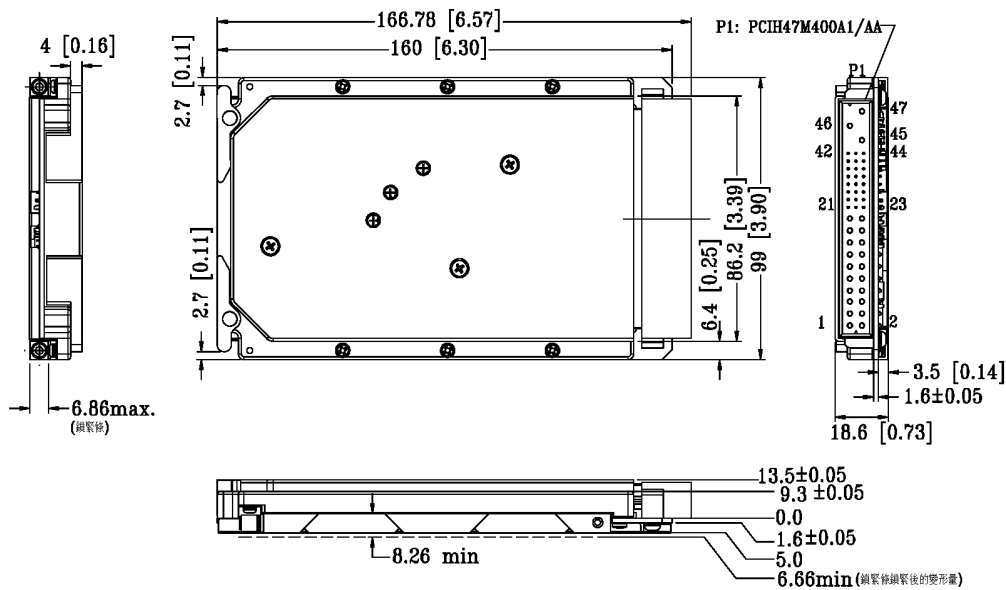

INPUT & OUTPUT CONNECTORS PIN ASSIGNMENT

ASSIGNMENT	PIN NO.
-Vin	47
+Vin	46
GND	45
VO1	1,2,3,4
VO2	13,14,15,16,17,18
VO3	20
VO4	21
DC COM	5,6,7,8,9,10,11,12,19,24
VO1 +Remote Sense	30
VO2 +Remote Sense	33
VO1/VO2 -Remote Sense	34
VO3 +Remote Sense	36
VO1 CS	35
VO2 CS	41
VO3 CS	44
EN#(Enable)	27
DEG #(Degrade Signal)	38
INH #(Inhibit Signal)	39
FAL #(Fail Signal)	42

Mating connector: PCIH47F400A1

DERATING CHART

